

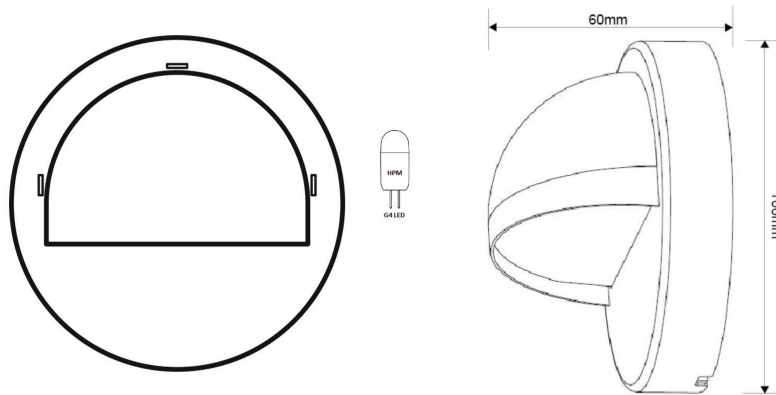

A brand of **legrand**

# LED Step Light - Round Instruction Manual

Cat. RGLLED002



RGLLED002

## 1 Specifications

Cat No	RGLLED002
Voltage	12Vac
Power	1W
IP rating	IP54
CCT	2700K
Lumen output	100 lm (lamp only)
Replacement globe	1W G4 LED Bi-Pin LAMP
Mounting	Plastic Ground stake
Wiring connection	Jaw Lock connector
Housing Material / Finish	Stainless Steel 304
Lifetime (Lamp)	6000hrs @ 25 °C
Warranty	1 yr Fixture Only

## 2 Globe Assembly

- STEP 1** Find 1x LED 1W G4 lamp in packaging (in a separate box).
- STEP 2** Undo 4x Screws at rear of fixture & separate the bracket from the fascia assembly.
- STEP 3** Push lamp in firmly into holder
- STEP 4** Screw bracket back in.

## 3 Cable Layout

If your installation includes multiple lights, HPM strongly recommends that you limit individual cable lengths to 20 metres, or use HPM heavier duty cable, otherwise lights may get progressively dimmer towards the end of the cable (voltage drop). See section for accessories

If your installation requires a total of more than 20 metres of cable, consider running two separate cables from the transformer output.

It is recommended that the LED lighting does not exceed 50% of the load rating of the transformer. Refer to section 'Choosing a suitable transformer' for further information

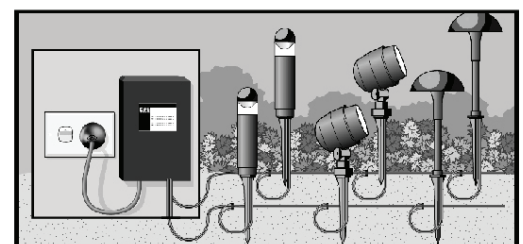

## 4 Installation

Note: Prior to installing your light, HPM recommends that you first observe the overall lighting effectiveness in the dark.  
To connect your garden lights, follow the instructions below:

**STEP 1** Place your garden lights in the approximate position you want them to be.

**STEP 2** Lay out the cable where you want your lights to be located, remembering to allow sufficient cable to connect to the transformer. Try to avoid laying the cable where frequent digging may occur.

### STEP 3 - Installation of a 12V Timer (if applicable)

If a 12 volt timer (HPM Cat No RGL10) is purchased, it must be positioned between the transformer and the lights. With the power turned off, connect the wire strands, on the end of the timer cable, into the output terminals of the transformer. Secure firmly with a screwdriver. **STEP 4 - Installation of the transformer**

Connect the cable to the transformer terminals (or timer, if applicable) by stripping back a small amount of insulation from each wire strand (approx. 10mm). Be careful not to damage wires. Twist wire strands to prevent loose wire escaping from terminal and to help ensure a tight connection. Place stripped ends into screw terminals on transformer, or timer, and secure firmly with a screwdriver.

**STEP 5** First connect the garden light that will be positioned the furthest away from the transformer.

The special connector on each light is designed to make electrical connection by piercing the insulation cable as the two halves of the connector are pushed together. (See connection diagrams).

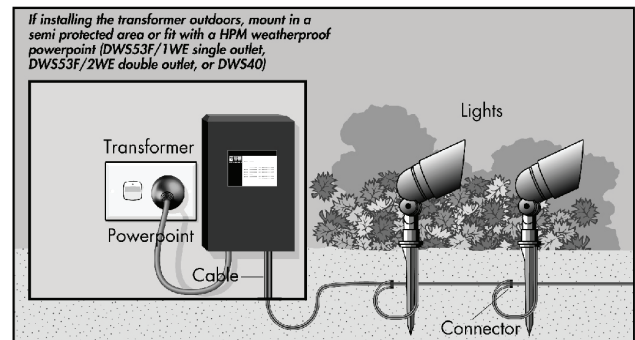

## 5 Connecting your garden lights

The special jaw lock connectors are designed to make electrical connection by piercing the insulation cable as the jaw lock connector is attached.

**STEP 1** Lay the cable flat on one half of the connector as shown.

**STEP 2** Lay the other half of the connector on top of the cable, upside down, taking care to align the pins into their matching holes on the other half. Push together firmly until they lock. Check that the two halves are pushed tightly together. (This will cause the spikes to deeply pierce into the copper centre of the cable and make a solid electrical connection).

**STEP 3** Plug the transformer into the powerpoint and check whether the furthest positioned garden light operates. (If it doesn't light up, refer to 'Troubleshooting' section page 4). If light does light up, switch off the transformer and proceed to connect all the other garden lights using the steps above.

To check each light connection is secure, first turn the transformer on from the powerpoint, then gently wiggle the cable and connector. (This is perfectly safe - the voltage at this point is very low). If the light flickers, the connection is not firm enough and should be re-connected (repeat 'Connecting your garden lights' Steps 1-2).

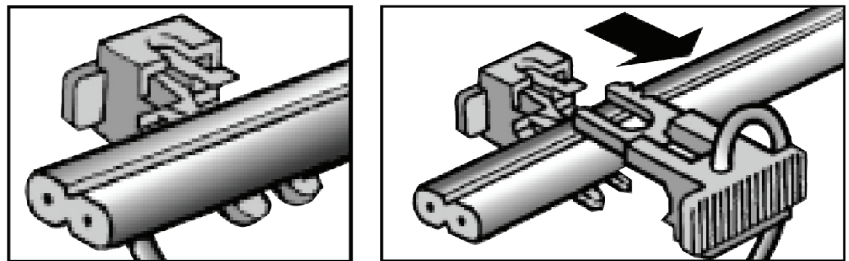

## 6 Setup

**STEP 1** Switch off the transformer from the powerpoint.

**STEP 2** If you wish to cover the cable in the ground, dig a narrow channel, about 100mm deep (just deep enough to hide the cable).

**STEP 3** Lay the cable at the bottom of the channel, or fasten the cable to the wall or step using appropriate fixings.

If your cable will be covered in the ground, we recommend, at this point, that you observe the overall lighting effectiveness in the dark before covering the channel.

## 7 Fixing

**STEP 1** Choose suitable location for mounting. Mark location for holes as shown in figure below, drill and fix screws (Use screws and lugs provided)

**STEP 2** Ensure the screw head face is proud off the wall face by 5mm.

**STEP 3** Now locate the screw head in the key-holes in the rear of the fixture and press down firmly into place.

If fixture is loose, repeat STEP 2 to adjust screw height and then follow STEP 3 again.

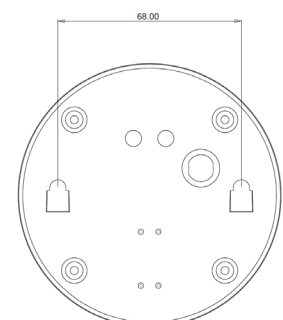

## 8 Globe replacement

To replace lamp follow instructions for Globe Assembly.

Note: If lamps do not turn ON or flicker when powered ON, repeat steps for Globe Assembly to see if there is a loose contact.

## 9 Choosing a suitable transformer

The total wattage of your LED garden lights must not be greater than ½ of the rating of the transformer.

For example if the RGLTR60 60W transformer is used then adding up the wattages of each LED light (e.g 4 x 6W = 24W) should not exceed the 30W max load.

Transformer	Load rating (incandescent lighting)	Load rating (LED lighting)
RGLTR60	60W	30W
RGLTR105	105W	50W
RGLTR220	200W	100W
RGLTR400	400W	200W
RGLPCTAW20	10W	5W

## 10 Accessories

### Outdoor Garden Cables:

RGL8 (2-core 1.3mm<sup>2</sup> 10m length)

RGL9 (2-core 1.3mm<sup>2</sup> 20m length)

RGLCL21/20 (2-core 2.1mm<sup>2</sup> 20m length)

RGLCL21/30 (2-core 2.1mm<sup>2</sup> 30m length)

RGLCL33/30 (2-core 3.3mm<sup>2</sup> 30m length)

RGLHSC15 (2-core 0.5mm<sup>2</sup> 15m length)

### Transformers:

RGLTR60

RGLTR105

RGLTR220

RGLTR400

RGLPCTAW20

### Sensor & Timers

(Compatible only with 60VA -200VA transformers)

RGL10 (200W sunset timer)

DGLS150 (150W dusk to dawn sensor)

### Connectors:

CDGLCC4 (pack of 4 cable connector)

## 11 Troubleshooting

Problem	Possible Solution
The powerpoint is turned on, but the lights are off.	<ol style="list-style-type: none"><li>1. The connections at the base of transformer may be loose. Tighten firmly</li><li>2. There is no power to the powerpoint, (Consult an electrician).</li><li>3. You may not have pierced the cable well enough with the metal spikes in the jaw-lock connectors. Check that the cable insulation has been fully pierced by the spikes.</li></ol>
Some lights are working, one or more are not.	<ol style="list-style-type: none"><li>1. If one or more of the lights are not working, first check the connection of the light to the cable (See 'Connecting your garden lights' section). If this is firm, check the globes by putting the 'non-working' globes into a working fitting. Replace unserviceable globes, (If applicable).</li></ol>
One or more lights flicker.	<ol style="list-style-type: none"><li>1. The connection to the light is loose. (See 'Connecting your garden lights' section).</li><li>2. The globe is loose. Push in firmly, (Watch out that globe is not hot). (HPM recommends paper or cloth be used to handle the globe).</li></ol>

## 12 Maintenance

### Outdoor Garden Cables:

To prolong the life of your Gardenlights HPM recommends the following:

- Install away from salty or corrosive environments
- Install away from highly fertilised areas
- Do not submerge in treated water such as chlorinated pools

To keep your lights looking new, keep lenses free of dust and residue by wiping occasionally with a dry cloth, or warm soapy water if necessary. If using soapy water, ensure that you thoroughly dry your light after cleaning.

## Warranty

Legrand warrants this product for a period of 1 year from the date of purchase when used in accordance with these instructions and considering the disclaimers listed herein.

These goods come with guarantees that cannot be excluded under the Australian and New Zealand Consumer Laws. You are entitled to a replacement or a refund for a major failure and for compensation for any other reasonably foreseeable loss or damage. You are also entitled to have the goods repaired if the goods fail to be of acceptable quality and the failure does not amount to a major failure.

See the Warranty card enclosed with this product for further details.

## Customer Service

For all Customer Service and Technical Support please call Monday to Friday during business hours.

Legrand Australia  
1300 369 777  
[www.hpm.com.au](http://www.hpm.com.au)

Legrand New Zealand  
0800 476 009  
[www.hpm.co.nz](http://www.hpm.co.nz)

ABN: 31 000 102 661

A Group brand |  **legrand**