

LWL093KBL

Please read instruction sheet before commencing installation. Installation must be performed by a registered electrical contractor.

## 1 Description

|                                     |                   |
|-------------------------------------|-------------------|
| <b>Cat. no.</b>                     | LWL093KBL         |
| <b>lumen package</b>                | 500lm             |
| <b>CCT</b>                          | 3000K             |
| <b>Supply Voltage</b>               | 230-240V a.c 50Hz |
| <b>Input Power</b>                  | 13W               |
| <b>Colour Rendering Index (CRI)</b> | 80+               |
| <b>Beam Angle</b>                   | N/A               |
| <b>Lifespan</b>                     | 35,000hrs @ 25°C  |
| <b>Dimmable</b>                     | N/A               |
| <b>IP Rating</b>                    | IP54              |
| <b>Warranty</b>                     | 5 yrs             |

## 2 LED Lamp Life

35,000 Hrs Rated Average Lamp LED Life @25°C.

## 3 Installation Instructions

Isolate 240V mains supply before opening fitting for maintenance or installation

Follow the steps below.

1. Remove 4 x screws & remove bracket from body.
2. Using mounting bracket as a template mark and drill holes for mounting.
3. Insert mains wires through silicone grommet. Fix the mounting bracket onto the wall with screws. Silicone should be added to screw heads and wire entry to ensure IP rating is maintained.
4. Silicone gasket must be used to maintain IP rating.
5. Connect the active, neutral and earth supply wires to the driver terminal.
6. Locate lamp assembly to bracket.
7. Fix the fixture to the mounting bracket using the grub screws supplied.

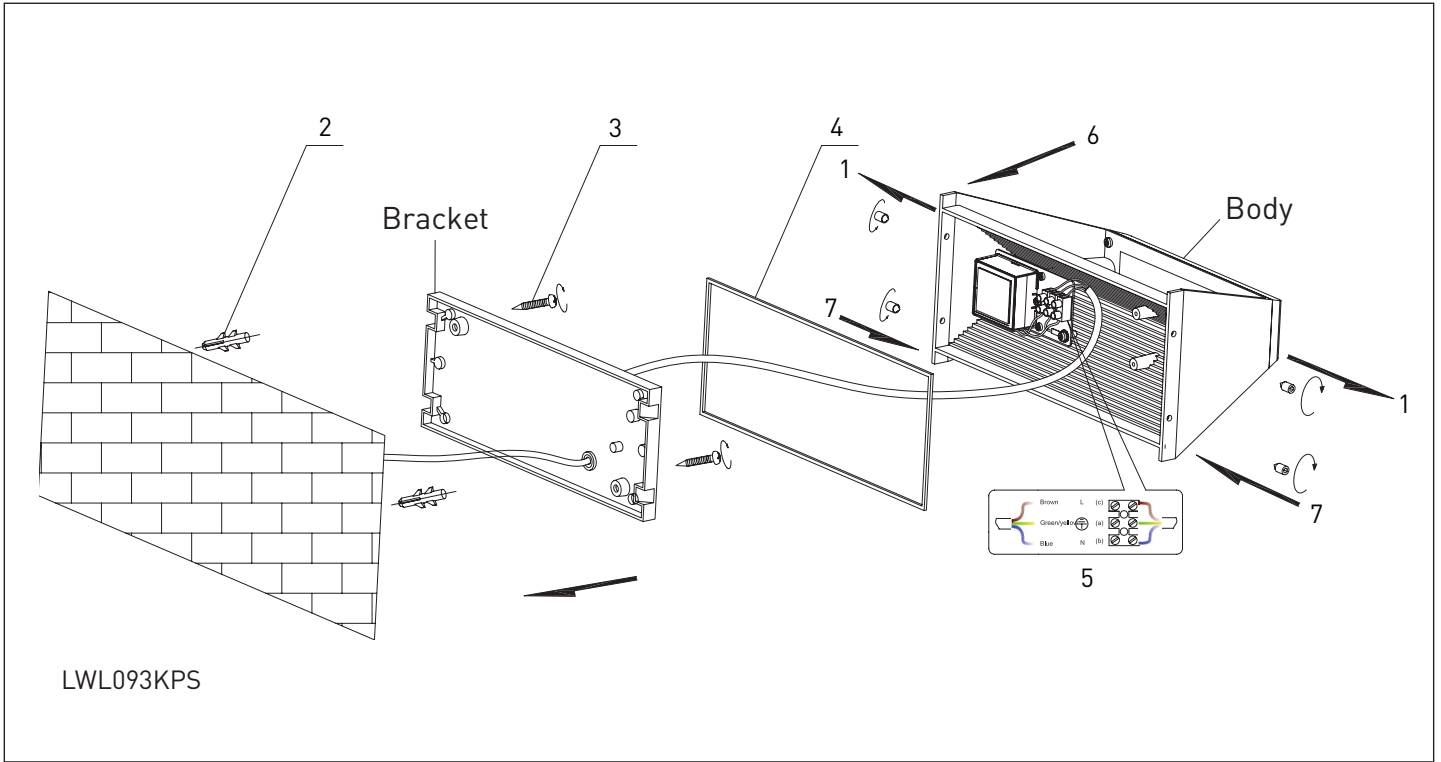

## Disclaimers

**1.** This product must be installed and used as per these instructions. **2.** This product should only be cleaned with a damp cloth. Cleaning agents and solvents should not be used. **3.** The IP rating of this product is only valid when installed on a flat and non-porous surfaces. Additional sealing may be required for irregular surfaces. **4.** This product has been designed to minimise the effects of interference from off peak electricity signals. Interference in the form of light flicker is still possible in some cases depending on proximity to the signal injection point. **5.** This product is not dimmable. **6.** This product contains no serviceable parts and no attempt should be made to repair this product. If the product is faulty it should be discarded. **7.** Severe electromagnetic interference from other products may cause malfunction of this product. **8.** The material in this product may vary in colour from batch to batch. Colour matching from one batch to another cannot be guaranteed. **9.** Electrical installations periodically receive transient over voltages. This product has been designed to minimise the effect of such voltages on connected equipment. It may not give full protection for extreme over voltage transients such as those resulting from a close lighting strike. **10.** Lamp LED life is an average and will be reduced by frequent switching. **11.** This product utilises intellectual property in the form of registered designs, trademarks, and/or patents. Such intellectual property remains the property of Legrand in all cases. **12.** This product has been designed to operate in ambient temperatures -5°C to 25°C, occasionally reaching 35°C. **13.** Legrand reserves the right to modify the specifications of this product at any time.

## Warranty

Legrand warrants this product for a period of 5 years from the date of purchase. These goods come with guarantees that cannot be excluded under the Australian and New Zealand Consumer Laws. You are entitled to a replacement or a refund for a major failure and for compensation for any other reasonably foreseeable loss or damage. You are also entitled to have the goods repaired if the goods fail to be acceptable quality and the failure does not amount to a major failure. See the Warranty card enclosed with this product for further details.

## Customer Service

For all Customer Service and Technical Support please call Monday to Friday during business hours.

Legrand Australia  
1300 369 777  
www.hpm.com.au

Legrand New Zealand  
0800 476 009  
www.hpm.co.nz

ABN: 31 000 102 661