

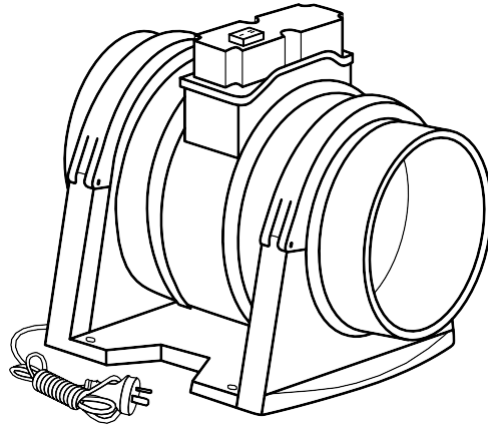

A brand of **legrand**

# Inline Exhaust Fan Kit-100mm & 150mm

Cat. No. EFIL100SQWE, EFIL150SQWE,  
EFTIL150SQWEKIT



## Instruction Manual

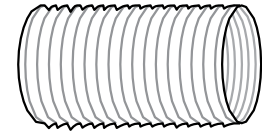
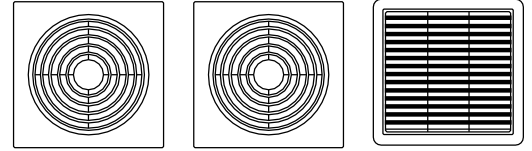

**Please read carefully:** Read through these instructions completely before commencing installation. Retain for future use. This product should be installed by a licensed electrical contractor or similarly qualified person.

### 1 Specifications

Cat. No.	EFIL100SQWE	EFIL150SQWE	EFTIL150SQWEKIT
Supply voltage	230-240V AC 50Hz		
Power rating	30W	60W	
Appliance class	Class II		
Standby power	N/A		<1W
IP rating	IP55		
Draught stopper	Yes (PET Sheet)		
Duct size	5m X Ø100mm	5m X Ø150mm	
Engine size	290 x 200 x 210mm	290 x 230 x 250mm	
Engine weight	1.9kg	3.0kg	
Power cord length	1m		N/A
Ceiling cut-out size (for inlet & outlet grilles)	Ø110mm	Ø160mm	
Warranty	5 year		3 year

Max airflow (m <sup>3</sup> /hr)	EFIL100SQWE		EFIL150SQWE / EFTIL150SQWEKIT	
Duct length	Low Speed (I)	High Speed (II)	Low Speed (I)	High Speed (II)
No duct	200	255	450	555
1m per side (total 2m)	100	125	310	390
2.5m per side (total 5m)	90	115	270	335

#### Sound Pressure Level: dBA at 3m (Tested in accordance with AS1217.5)

EFIL100SQWE		EFIL150SQWE/ EFTIL150SQWEKIT	
High Speed (II)	Low Speed (III)	High Speed (I)	Low Speed (III)
38	34	47	42

### 2 Features

The inline fan is designed to extract steam and odours from a bathroom and expel it to the exterior through an eave outlet. It is also suitable for extracting air from one room and expelling it to another room (heat distribution).

The fan engine is fitted into the ceiling, well away from the inlet. This inline feature allows the inlet grille to be mounted in wet areas (near the splash zones of bathrooms) or even above the shower. And because the motor is in the ceiling cavity (away from the inlet grille), noise from the fan is minimal.

### 3 Things to consider

1. This product shall be installed in accordance to AS/NZS 3000 Wiring Rules.
2. This product is meant for indoor use only.
3. Regulations concerning the discharge of air must be fulfilled. Local building codes may require venting to the outside.
4. Do not locate the inlet grille above a stove. This product is not to be used in conjunction with a kitchen range hood exhaust system.
5. The minimum length of duct between the fan engine and the inlet / outlet grilles is 200mm.
6. Cross Ventilation:  
Ventilation products must have an adequate source of external air to ensure rated performance.  
Steam and air will only be exhausted through the fan if there is sufficient flow of air through the room. Ensure adequate inlets exist through windows, vents or under the door. Airflow path from the inlet to the fan should ideally pass over the source of steam or air to be removed from the room.  
Restrictions on replacement air entering the room to be ventilated, or pressure-differentials between the room and outside air will significantly reduce the exhaust fan's performance.
7. Unit location:  
The fan engine should be positioned at the highest point on the system so the ducting will slope downwards to both grilles. Refer to Fig. 2.  
Do not cover the fan engine with thermal insulation. Keep at least 100mm clearance between the engine and thermal insulation.  
The fan engine should not be located in an area containing excessive levels of grease.  
When choosing a location for the wall switch, ensure it is not within arm's reach or accessible to a person in a bath or shower.
8. Unit Orientation:  
The unit must be installed to ensure the fan inlet, outlet and ducting are oriented in parallel to any roofing structures or supports. Refer to Fig. 1 for correct installation orientation.  
Orientation which forces the unit to be ducted into a 90° bend immediately after the fan inlet/outlet will cause a significant performance reduction.
9. Duct Routing:  
As the back pressure increases the unit's performance is reduced. Airflow will be reduced with bends in duct or squashing of duct.  
When fitted, the inlet & outlet grilles must be lower or same level as inline fan engine. Refer to Fig. 2 and 3.  
The duct must not be installed vertically into a roof vent cap - the product is not designed or intended for this type of installation. Refer to Fig.4.

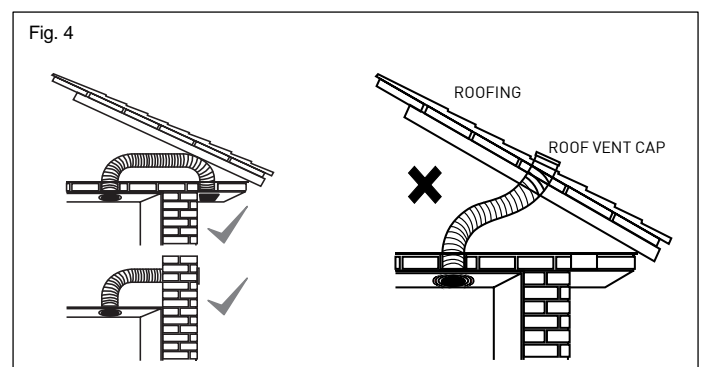
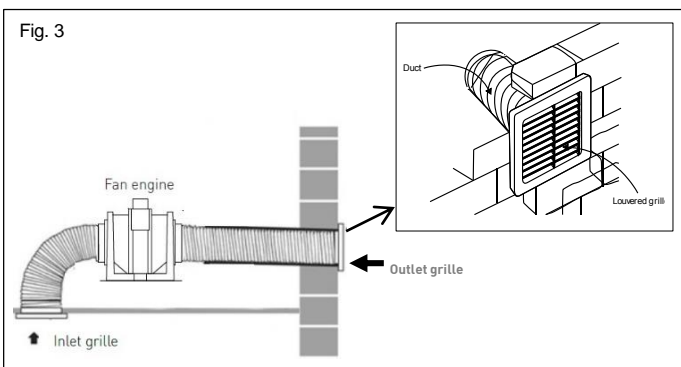
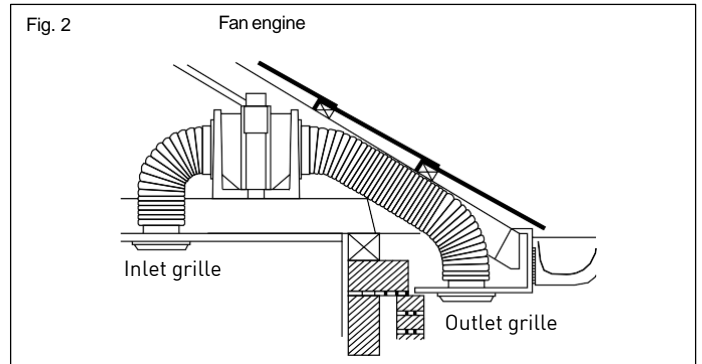
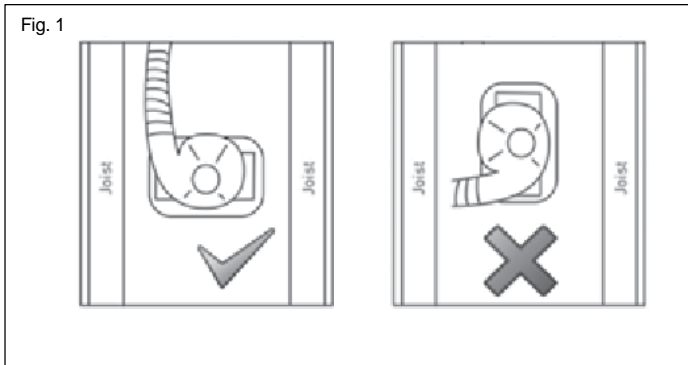

## 4 Inlet and Outlet Grilles

Fig 5: 2 types of grilles are supplied with this product.

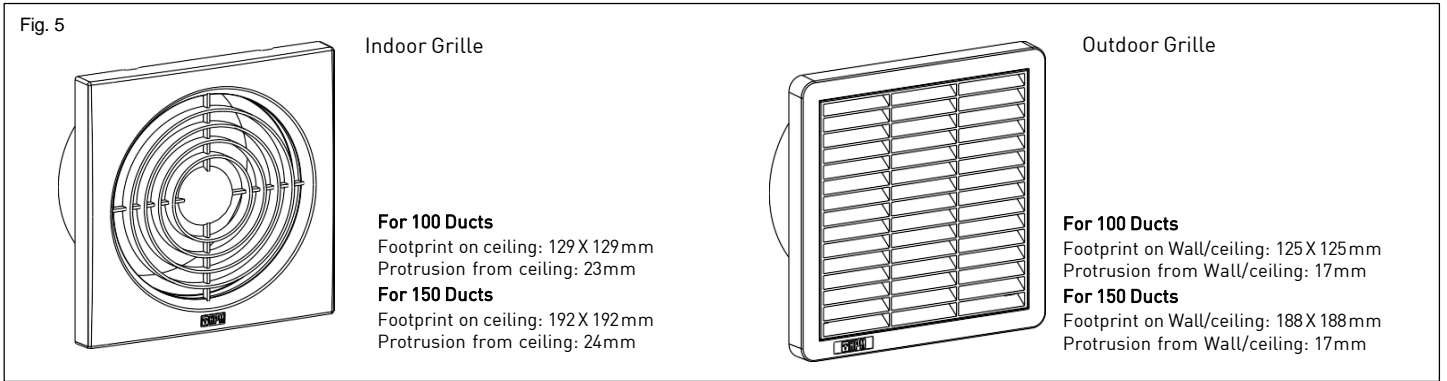
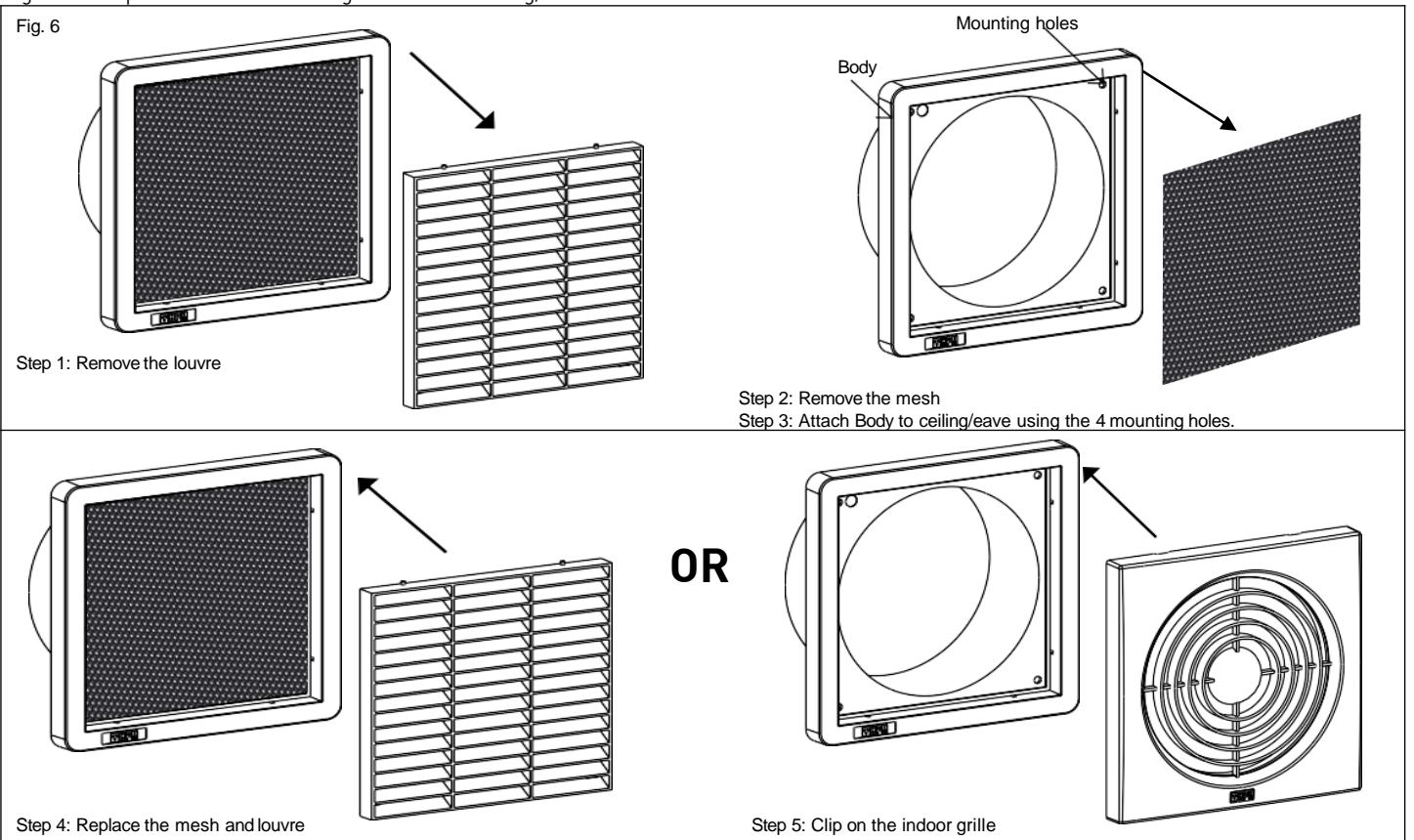
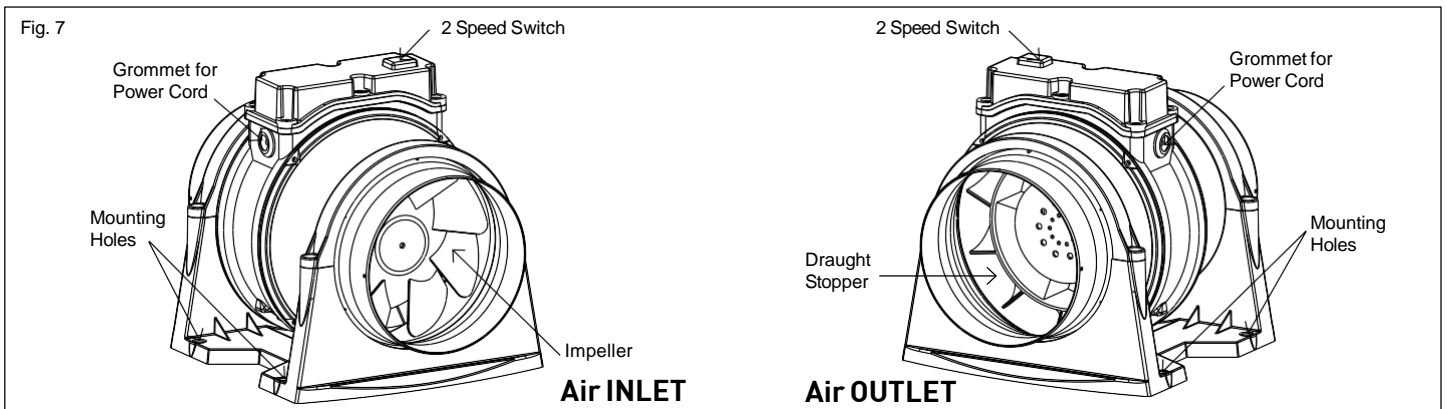

Fig. 6: Description how to mount the grille onto the ceiling/eave.



## 5 Fan Engine



Orientation of the junction box can be adjusted to suit the fan engine's mounting location.

1. Unscrew and open the engine clamps.
2. Rotate the Engine to the desired position of the junction box.
3. Replace the engine clamps and tighten the screws.

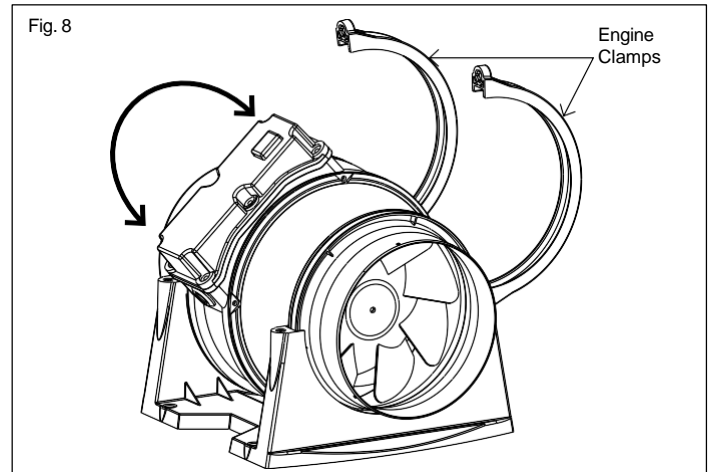

## 6 Installation

Before commencing installation, remove all packaging from the product and ensure that power to the circuit has been isolated.

1. Choose a suitable mounting location for the inlet grille. Ensure there is adequate clearance from studs, pipes, wires etc (Fig. 9).
2. Cut a  $\varnothing 160\text{mm}$  hole in the ceiling (Fig. 10).
3. Repeat steps 1 & 2 for the outlet grille.
4. Choose a suitable mounting location for the fan engine. Ensure that a power outlet is installed near the intended location of the engine.
5. Mount the engine to a suitable support using the mounting screws provided or other suitable fixings (not provided). The engine should be positioned so that the power cord is pointing downwards.
6. Stretch, measure and cut the expandable duct to fit between each grille and the fan engine. To obtain optimum performance, the duct should be fully stretched and without any holes or splits.
7. Attach duct to the outlet grille using the cable ties provided. Pass the duct through the outlet hole and mount the outlet grille to the ceiling / eave.
8. Slide the free end of the duct onto the outlet end of the fan engine and secure it with duct tape.
9. Attach duct to the inlet grille using the cable ties provided. Pass the duct through the inlet hole and mount the inlet grille to the ceiling.
10. Slide the free end of the duct onto the inlet end of the fan engine and secure it with duct tape.
11. Set the Speed Switch to the desired speed (0 - Off, I - Low, II - High).
12. Plug the fan engine into the power outlet (Fig.11) or terminate wires as shown in Fig 12.
13. Switch on the inline fan and test function. Use a paper tissue held against the inlet grille to verify suction.

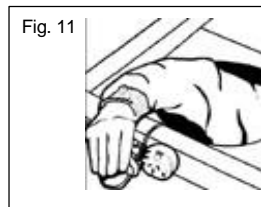
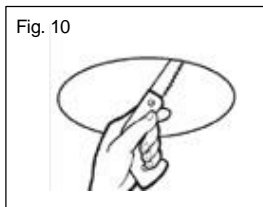
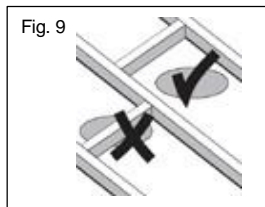

## 7 Wiring

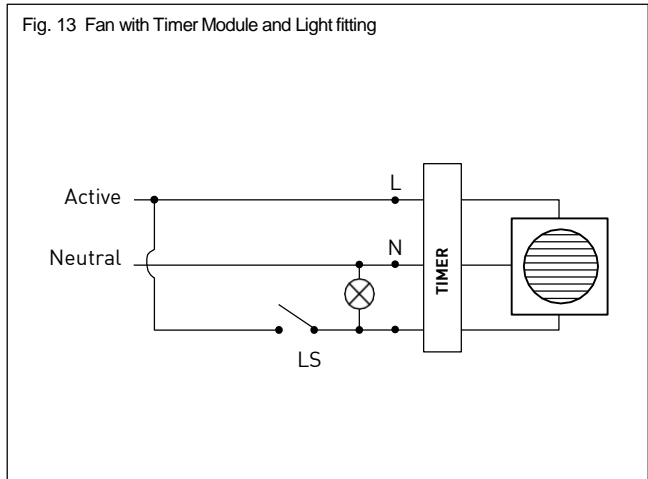
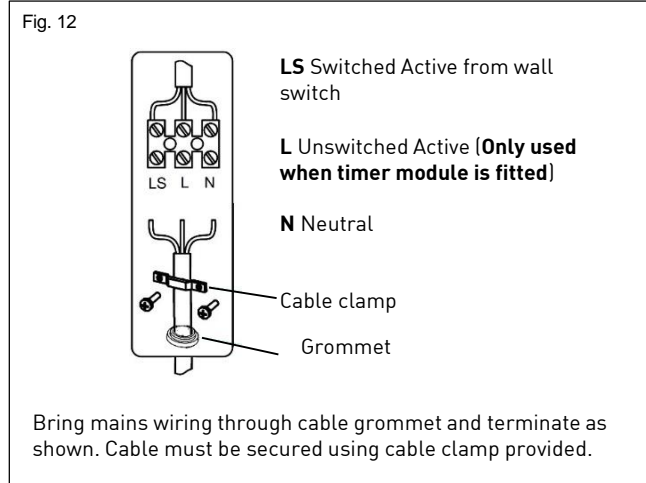

## 8 Timer function

Condition	Timer Module
LS is Powered OFF (Initial)	Fan does not run
LS is Powered ON	Fan runs continuously
LS is Powered OFF	Fan runs for Preset time and Switches OFF
LS is Powered ON and OFF immediately	Timer is Reset and fan runs for Preset time and Switches OFF

Fig. 14

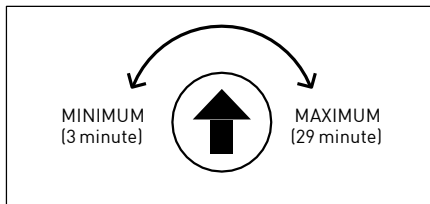

### Timer Adjustment

The default setting is to 3 min (approx). Adjust to desired time delay.

## 9 Product Notes

1. This product must be installed and used as per these instructions.
2. This product should only be cleaned with a damp cloth. Cleaning agents and solvents should not be used.
3. This product is not intended for use by persons (including children) with reduced physical, sensory or mental capabilities, or lack of experience and knowledge, unless they have been given supervision or instruction concerning use of the appliance by a person responsible for their safety.
4. Children should be supervised to ensure that they do not play with the appliance.
5. This product is intended for household use and similar purposes. It is not suitable for use in an environment heavily laden with dust. Under these conditions the life of the fan motor can be significantly reduced.
6. This product should not be enclosed in thermal insulation as it may cause the unit to overheat.
7. This product has been designed to operate in ambient temperatures 0°C to 50°C.
8. This product contains no serviceable parts and no attempt should be made to repair it. If the product is faulty it should be discarded.
9. If the supply cord is damaged, it must be replaced by Legrand, its service agent or a similarly qualified person in order to avoid a hazard.
10. Airflows listed in this product indicate the product performance. Refer to the BCA (Building Code of Australia), or similar, for the appropriate airflow required for a particular installation.
11. Ventilation products must have an adequate source of external air to ensure correct performance.
12. Consideration must be taken in the installation of ducts to ensure that condensation that will form in the duct will not run into the fan engine.
13. Precautions must be taken to avoid the back-flow of gases into the room from the open flue of gas or other fuel-burning appliances.
14. This product has been designed for domestic or similar uses and is not suitable for a commercial installation.
15. This product is not suitable for installation in hazardous and/or corrosive areas.
16. Extended exposure to UV rays (such as exposure to direct sunlight) may cause discolouration of this product.
17. The material in this product may vary in colour from batch to batch. Colour matching from one batch to another cannot be guaranteed.
18. This product utilises intellectual property in the form of registered designs, trademarks, and/or patents. Such intellectual property remains the property of Legrand in all cases.
19. Legrand reserves the right to modify the specification of this product at any time.

### Warranty

Legrand warrants this product for a period of specific years from the date of purchase. (Please refer to specification table). These goods come with guarantees that cannot be excluded under the Australian and New Zealand Consumer Laws. You are entitled to a replacement or a refund for a major failure and for compensation for any other reasonably foreseeable loss or damage. You are also entitled to have the goods repaired if the goods fail to be acceptable quality and the failure does not amount to a major failure.

See the Warranty card enclosed with this product for further details.

### Customer Service

For all Customer Service and Technical Support please call Monday to Friday during business hours.

Legrand Australia  
1300 369 777  
www.hpm.com.au

Legrand New Zealand  
0800 476 009  
www.hpm.co.nz

ABN: 31 000 102 661