

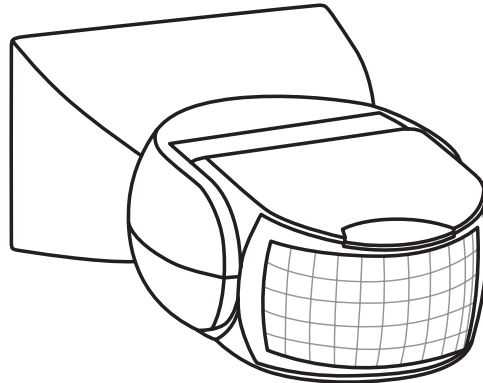

PIR Movement Sensors

Cat. No. 630S01WE, 630S01BL, 630SM01WE, 630SM01BL

Instruction Manual



This product must be installed by a licensed electrician.

1. Specifications

Cat. No.	630S01WE	630S01BL	630SM01WE	630SM01BL
Detection Method	Passive Infrared (PIR)			
Supply Voltage	230-240V a.c. 50Hz			
Terminal Wiring Size	1 x 2.5mm ² to 2 x 1.5mm ²			
Standby Power	< 1.0W			
Detection / View Angle	180°			
Detection Range / Distance	12m max (at ≤ 24°C)			
Recommended Mounting Height	1.8m to 2.5m			
Lux Adjustment Range	3 lux to 2000 lux			
Time Adjustment Range (approx)	10 ± 3 sec to 15 ± 2 min			
Switching Function	Auto Mode only		Auto Mode / Manual Override	
IP Rating	IP44			
Weight	160g			
Colour	White	Black	White	Black

Maximum Lighting Load	630S01WE	630S01BL	630SM01WE	630SM01BL
Incandescent	1200W			
Fluorescent	400VA			
Compact Fluorescent Lamp (CFL)	300VA			
LED	300VA			

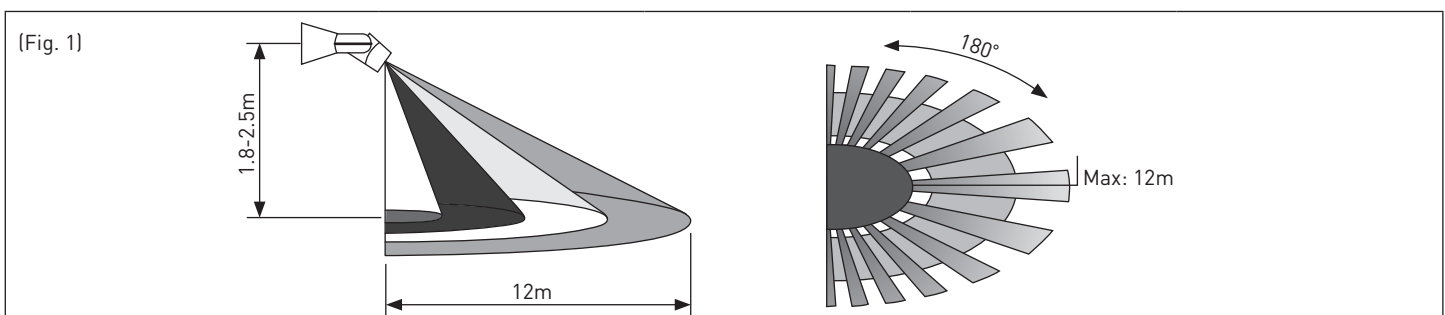

2. Sensor locations to be avoided

1. Near water features such as swimming pools or ponds. The movement and reflections are likely to create nuisance switching.
2. Near heat sources such as air conditioners, dryers, heaters or barbecues.
3. Locations which are subject to drastic changes in temperature.
4. Locations which are subject to bright light such as direct sunlight.
5. Locations frequented by animals such as pets or birds.

3. Where to mount your movement sensor

Before selecting a place to install your movement sensor, you should note that movement across the scan area is more effective than movement directly toward or away from the sensor (refer to Fig. 2). If movement is made walking directly towards or away from the sensor and not across, the apparent detection range will be substantially reduced.

Always mount the sensor in a sheltered position, i.e. under the eaves of the house.

Ideally, the sensor should be mounted 1.8m to 2.5m above the area to be scanned (refer to Fig. 1).

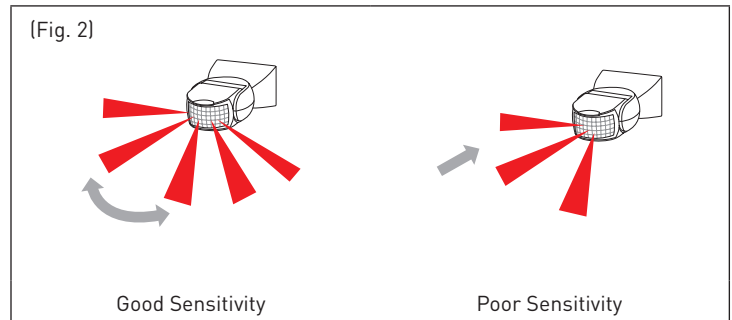

4. Installation

Switch off power source before installation.

Ensure the power supply wiring comes from a circuit protected by a suitable fuse or circuit breaker.

We recommend installing a wall switch for electrical isolation of the sensor.

1. Remove the mounting bracket from the unit by loosening the screw on the bottom (Fig. 3).
2. Use the mounting bracket as a template to mark the screw positions onto the wall / ceiling. Ensure that the orientation of the mounting bracket is such that the TIME & LUX controls are at the bottom of the unit (Fig 4).
3. Insert the supply & load cables through the grommets on the mounting bracket.
4. Install the mounting bracket onto the wall / ceiling.
5. Connect the supply & load cables to the terminal block as shown in (Fig. 5). Ensure that the wires are secure and no bare wires are exposed. This is a class II item, ensure this is maintained during installation.
6. Install the unit back onto the mounting bracket and tighten the screw on the bottom.
7. Adjust the sensor head to the desired position.

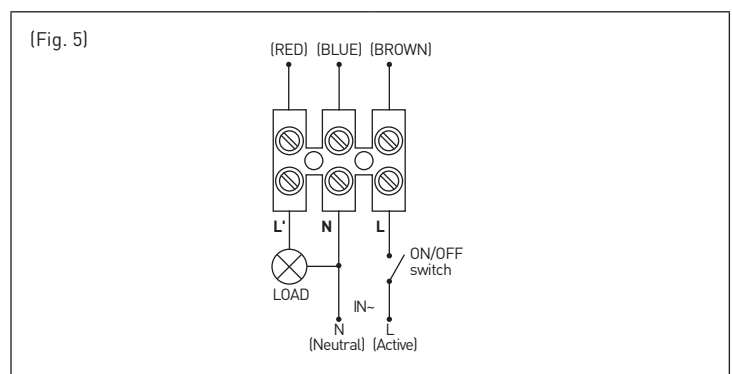
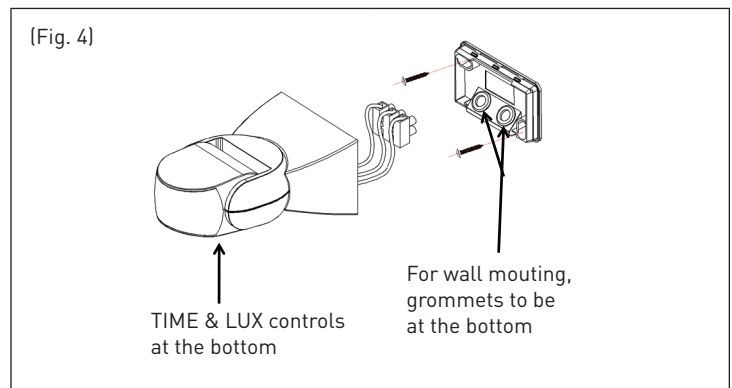
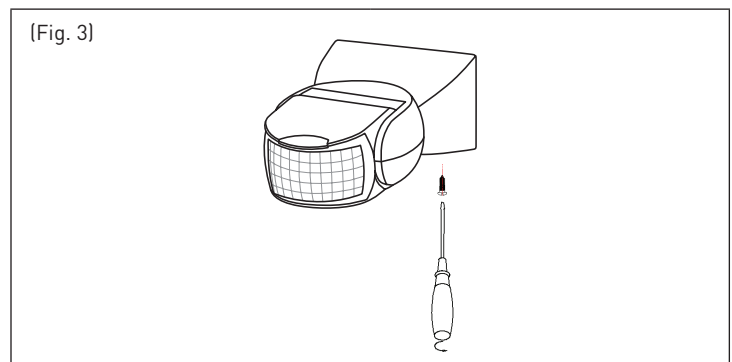

5. Setting the Controls

With the Sensor fully installed by an electrician and power on

1. Turn the TIME knob to minimum and turn the LUX knob to maximum as shown in (Fig. 6).
2. Turn the wall switch on. The light/s should turn on immediately and will remain on while the sensor warms up, for approximately 30 seconds. It will then turn off.
3. Walk through the coverage area and the light should turn on. This confirms that the wiring is correct and that the light is operational.
4. Adjust the TIME knob to your desired setting.
5. To set the ambient light level at which the sensor will switch on, turn the LUX knob to its fully anti-clockwise position. Wait for the desired ambient light level, then turn the LUX knob clockwise while someone walks through the coverage area. When the light switches on, release the LUX knob.

(Fig. 6)

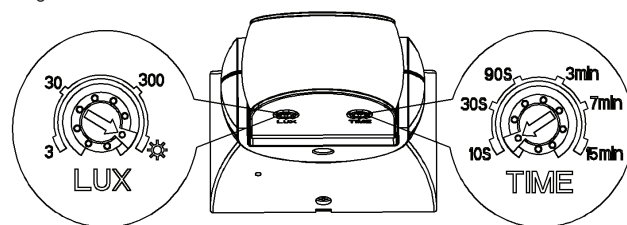

6. Time Adjustment

The TIME knob controls how long the light/s will stay on after movement is detected. Rotating the TIME knob clockwise increases the duration time. The duration time varies between approximately 10 seconds (minimum) to approximately 15 minutes (maximum).

Note: Once the light has been triggered by the PIR sensor, any subsequent detection will start the timed period again from the beginning.

7. Lux Adjustment

The LUX knob controls the ambient light level at which the sensor will switch on. At the fully clockwise position, the sensor will operate 24 hours a day. At the fully anti-clockwise position, the sensor will only operate at night. You can set the sensor to operate at the desired lux level by adjusting the LUX knob.

8. Manual Override (for 630SM01WE & 630SM01BL only)

1. When power is first switched on, the unit enters into the WARM UP period for about 30 seconds, then automatically changes into AUTO MODE.
2. During AUTO MODE, by switching the ON/OFF main switch off & on twice in about 3 seconds, the unit will automatically change into MANUAL MODE. In MANUAL MODE, the unit will remain ON and it will not be affected by the TIME and LUX control levels. The unit will remain in MANUAL MODE until the ambient light level reaches 100 lux (daylight), at which point it will change back to AUTO MODE.
3. During MANUAL MODE, by switching the ON/OFF main switch off & on twice in about 3 seconds, the PIR detector will automatically change into AUTO MODE.
4. During AUTO MODE or MANUAL MODE, by switching off the ON/OFF main switch over 10 seconds and then on again, the PIR detector will reset to WARM-UP period.

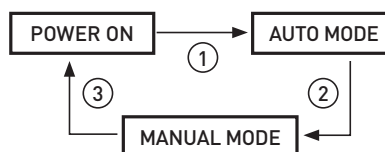

9. Maintenance / Cleaning

This product should only be cleaned with a damp cloth. Cleaning agents and solvents should not be used.

10. Troubleshooting

PROBLEM	POSSIBLE CAUSE	POSSIBLE SOLUTION
Light does not switch on when there is movement in the coverage area.	1. Power not available	Check connections, switches and fuse.
	2. Faulty light/globe.	Replace light/globe.
	3. Incorrect wiring.	Recheck all wiring.
	4. Controls set incorrectly.	Change light adjustment (LUX knob).
	5. Nearby lighting is too bright.	Relocate the unit.
Light switches on for no apparent reason. (False triggering)	1. Heat sources (such as air conditioner, heater, dryer or barbecue) are activating the sensor.	Relocate the unit.
	2. Animals (birds, pets etc)	Possibly unavoidable.
	3. Interference on the same circuit from on/off switching of other electrical devices.	a. Check/Replace faulty switches. b. Replace noisy fluoro tubes/starters. c. Connect the unit to a different circuit.
	4. Reflective objects (such as swimming pool) in the coverage area.	Relocate the unit.
Light does not switch off after set time has elapsed.	1. Time is set for too long.	Reduce time (TIME knob).
	2. Wiring is incorrect.	Recheck all wiring.
	3. Unit damaged due to maximum load exceeded or incompatible load type or failure of the load (such as short circuit).	Identify and fix the cause of the failure. Replace the unit with a new one.
	4. Unit is in MANUAL MODE.	Change to AUTO MODE.
Light switches on during daylight.	1. LUX knob is set to daylight position.	Turn the LUX knob anti-clockwise to suit desired light setting.
When setting the controls in daylight the detection distance becomes shorter.	1. Interference by sunlight.	Re-set controls at night.

9. Disclaimers

1. This product must be installed and used as per these instructions.
2. An IP rating of IP44 is generally considered suitable for external walls with supplementary protection such as overhanging eaves.
3. The IP rating of this product is only valid when installed on a flat and non-porous surface. Additional sealing may be required for irregular surfaces.
4. This product must be used with the loads specified only. Other load types should be used only when written confirmation is given by HPM Legrand.
5. This product contains no serviceable parts and no attempt should be made to repair this product. If the product is faulty it should be discarded.
6. This product is not suitable for installation in hazardous and/or corrosive areas.
7. Electrical installations periodically receive transient over voltages. This product has been designed to minimise the effect of such voltages on connected equipment. It may not give full protection for extreme over-voltage transients such as those resulting from a close lighting strike.
8. This product utilises intellectual property in the form of registered designs, trademarks, and/or patents. Such intellectual property remains the property of HPM Legrand in all cases.
9. This product has been designed to operate in ambient temperatures -10°C to 40°C.
10. Extended exposure to UV rays (such as exposure to direct sunlight) may cause discolouration of this product.
11. The material in this product may vary in colour from batch to batch. Colour matching from one batch to another cannot be guaranteed.
12. HPM Legrand reserves the right to modify the specification of this product at any time.

Warranty

HPM Legrand warrants this product for a period of 3 years from the date of purchase.

These goods come with guarantees that cannot be excluded under the Australian and New Zealand Consumer Laws. You are entitled to a replacement or a refund for a major failure and for compensation for any other reasonably foreseeable loss or damage. You are also entitled to have the goods repaired if the goods fail to be acceptable quality and the failure does not amount to a major failure.

See the Warranty card enclosed with this product for further details.

Customer Service

For all Customer Service and Technical Support please call Monday to Friday during business hours.

HPM Legrand Australia
1300 369 777
www.hpm.com.au

HPM Legrand New Zealand
0800 476 009
www.hpm.co.nz

ABN: 31 000 102 661

A Group Brand | 

LE09423AEA